

Series TSdv F75

Spec Sheet



THOR SYSTEMS, INC.
 3621 Saunders Avenue
 Richmond, VA 23227-4354
 Ph 804.355.1100 - www.thorsystems.us



** Image is not model specific **

Coax Cable SPD

- 48V Coax Cable Applications
- Wall Mount
- Surge Rated
- 1, 2 or 4-Port Models
- Line - Ground Protection
- Type 'F' Coax Cable Connection

GENERAL SPECIFICATIONS

Application	Coax Cable SPD
Connection Method	Fig. A - Series
Technology	Fig. B - Gas Tube
Protection Modes	Line-Ground
Warranty	2 Years

ELECTRICAL SPECIFICATIONS

Nominal Voltage	48v
Max. Operating Voltage (MCOV)	60v
Max. Surge Current	15kA
Max. Line Current (OCPD Size)	500mA
Max. Data Rate	Up to 3GHz
Ambient Temperature	-40°C to 85°C

MECHANICAL SPECIFICATIONS

Termination Method	Type 'F' Coax Connector
Disconnect Indication	Transmission Interrupt
Housing	DIE Cast NEMA 1 (IP10)
Dimensions	See Fig. C
Mounting	Wall Mount
Outdoor Use	No

AVAILABLE MODEL NUMBERS

Model#	Input/Output Jacks
TSdv F75 W01 060 FF	1
TSdv F75 W02 060 FF	2
TSdv F75 W04 060 FF	4

Fig. A__ - CONNECTION METHOD

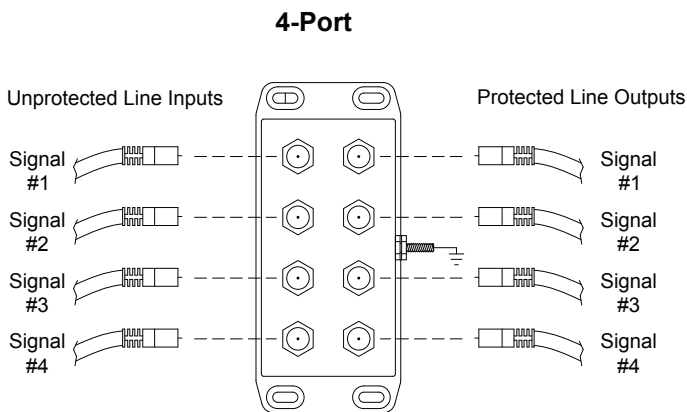
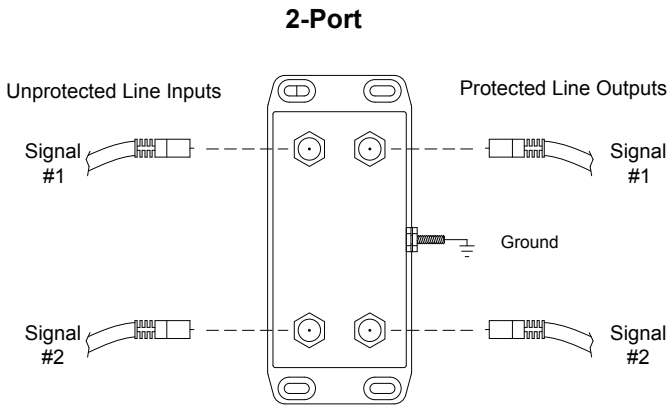
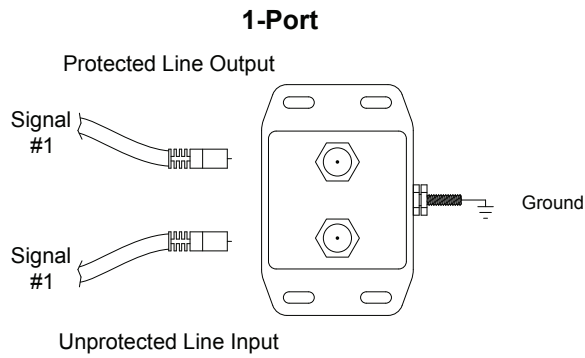

Fig. B - TECHNOLOGY / SCHEMATIC

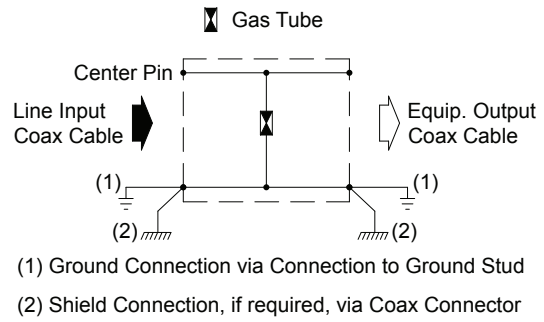

Fig. C - DIMENSIONS

